

Single Tee Spec Sheet

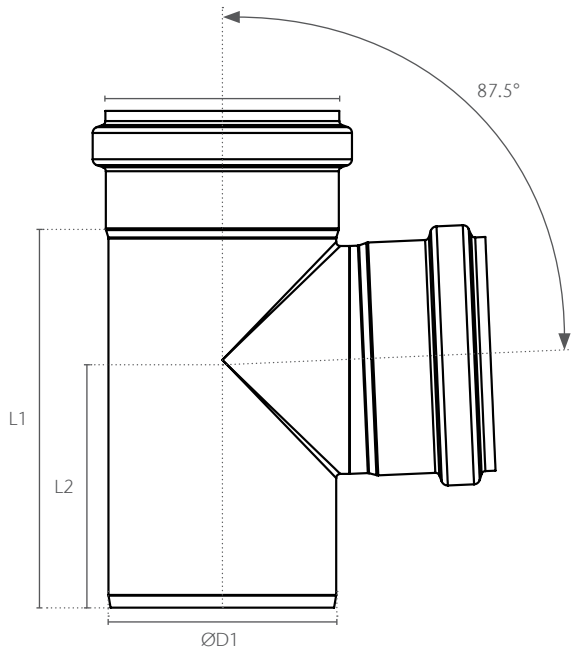

Part No.	Length (L1) in (mm)	Length (L2) in (mm)	ØD in (mm)	Gasket Material	Pipe Material	Weight lbs
417368	3.98 (101)	2.72 (69)	1.57 (40)	EPDM	316L	0.6
98782	4.18 (106)	2.80 (71)	1.97 (50)	EPDM	316L	0.6
98784	5.48 (139)	3.55 (90)	2.95 (75)	EPDM	316L	1.1
98786	7.21 (183)	4.61 (117)	4.33 (110)	EPDM	316L	2.0
419750	8.67 (220)	5.32 (135)	4.92 (125)	EPDM	316L	2.9
98788	11.34 (288)	7.25 (184)	6.30 (160)	EPDM	316L	5.3
419421	13.12 (333)	8.12 (206)	7.87 (200)	EPDM	316L	9.5
417104	14.30 (363)	8.47 (215)	9.84 (250)	EPDM	316L	12.8
417208	18.75 (476)	11.07 (281)	12.40 (315)	EPDM	316L	32.5

Specification Summary

Used with ACO Pipe System. Made from AISI 316L. Resistant to thermal and dynamic shocks. Rodent-proof and sagproof. Non-combustible. Double-lipped seal push-fit connection. Designed for gravity piping system with maximum working pressure of 0.5 bar. Socket clamps, NBR and FPM gasket material also available upon request. Socket clamp can increase maximum operating pressure to 0.7 bar.

ACO recommends checking local plumbing codes prior to installation. Manufactured to EN 1124-1 and 1124-2.

ACO, Inc.

© January 2026 ACO, Inc.

All reasonable care has been taken in compiling the information in this document. All recommendations and suggestions on the use of ACO products are made without guarantee since the conditions of use are beyond the control of the company. It is the customer's responsibility to ensure that each product is fit for its intended purpose and that the actual conditions of use are suitable. ACO, Inc. reserves the right to change products and specifications without notice.

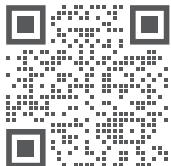

info@acousa.com
www.acousa.com

